



## 45A Control Switches



### Range of Simply Stylish Wiring Accessories

Designed to provide a competitive, cost effective equivalent range of white moulded accessories with a sleek, slim design creating a modern aesthetic.

Manufactured from Polycarbonate with reinforced interior plates to ensure every product is robust, strong, durable and UV stabilised so that signs of ageing is not a problem.

**45A Control Switches**

**Product Range**

**45A Control Switches**

<b>CPC200</b>	45A Double Pole 1 Gang Plate Switch
<b>CPC201</b>	45A Double Pole 1 Gang Plate Switch With Neon
<b>CPC202</b>	45A Double Pole 2 Gang Plate Switch (Vertical)
<b>CPC203</b>	45A Double Pole 2 Gang Plate Switch With Neon (Vertical)



CPC200



CPC201



CPC202



CPC203

45A Control Switches

Product Dimensional Drawings (mm)

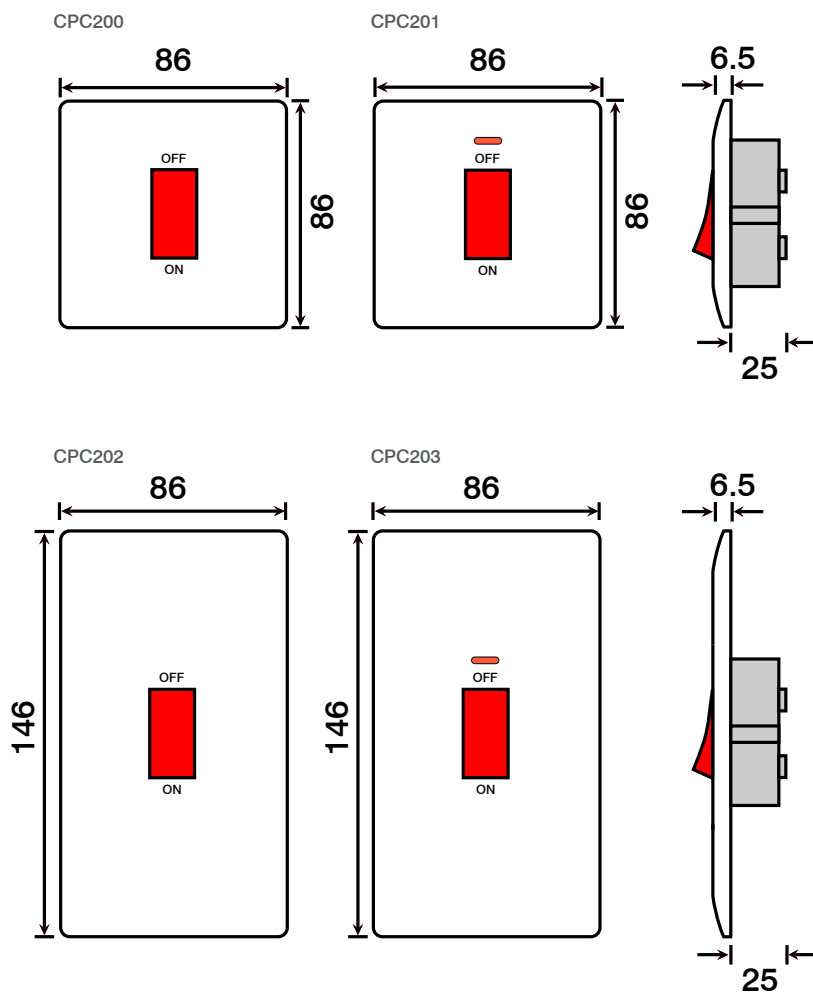

45A Control Switches

Product Wiring Diagram

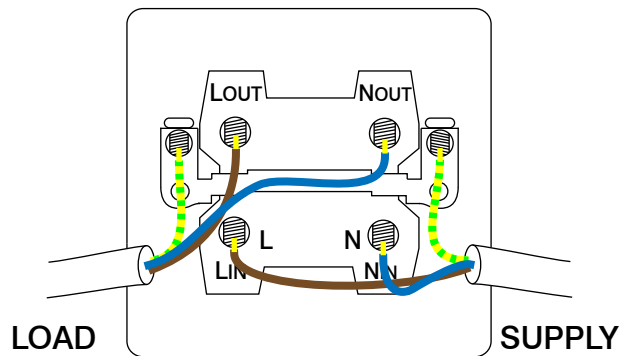

## 45A Control Switches

### Technical Specification

#### 45A Control Switches

<b>Material Composition</b>	Front Plate, Switch & Neon Lens: Polycarbonate Insert & Base: Polycarbonate Terminals: Brass Plated Steel Terminal Screws: Steel and Yellow Passivated Internal Mechanism: Formed Press Brass Silver "On-lay" Copper / Brass Contacts
<b>Voltage</b>	250V~ 50Hz
<b>Current Rating</b>	45A
<b>Terminal Screw</b>	6.0mm $\varnothing$
<b>Torque Value</b>	2.5Nm
<b>Terminal Capacity</b>	16mm <sup>2</sup> Max
<b>Fixing Centres</b>	1 Gang: 60.3mm, 2 Gang: 120.6mm
<b>Back Box Depth</b>	35mm
<b>Warranty</b>	10 Years Domestic
<b>Operational Temperature</b>	-5° to +40°C
<b>Standards</b>	The Low Voltage Directive 2014/35/EU BS EN 60669-1: 1999 +A1: 2002 +A2: 2008

### Additional Information

Ensure that the mains supply is isolated before commencing installation and refer to the circuit diagram with the relevant product.

Bare earth cables must always be covered with appropriate sleeving and wired to the earth terminal.



## EU DECLARATION OF CONFORMITY

1. *Issuer Name* Scolmore International Limited
2. *Issuer Address* 1 Scolmore Park, Landsberg,  
Lichfield Road Industrial Estate,  
Tamworth, Staffordshire, B79 7XB
3. *Object(s) of Declaration* Seera Range
  - a. *Group* 45A Control Switches
  - b. *Model No.* CPC200, CPC201, CPC202 & CPC203
4. *The object of the declaration described above is in conformity with the requirements of the following Legislations:*

The Low Voltage Directive 2014/35/EU

5. *All products contained within the aforementioned comply with the relevant standards and requirements listed below.*

BS EN 60669-1: 1999 +A1: 2002 +A2: 2008

6. *I hereby declare that the equipment named above has been designed to comply with the relevant sections of the above referenced specifications. The unit complies with all applicable Essential Requirements of the Directives.*

*In conjunction with the above all manufacture and process controls are in accordance with ISO 9001:2015.*

*This declaration has been issued under the sole responsibility of the manufacturer, signed at, for and on behalf of: Scolmore International Limited*

A handwritten signature in black ink, appearing to read "Karl Rawlins".

Karl Rawlins – Senior Technical Support Engineer